

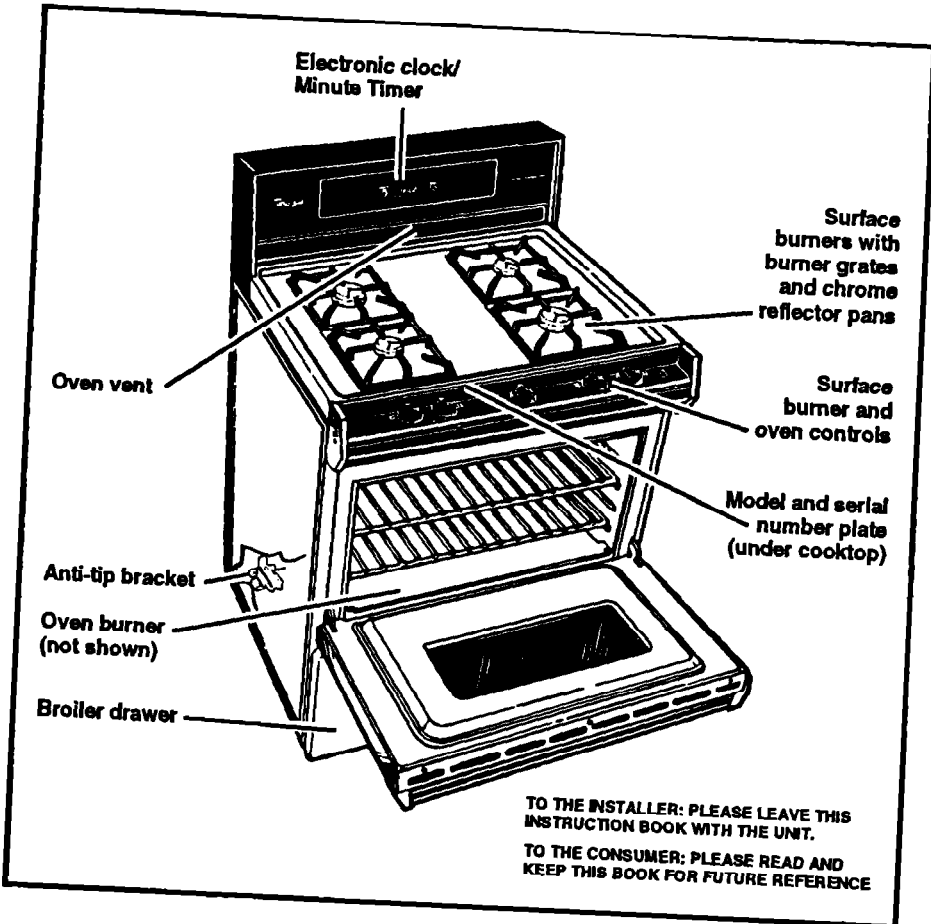

Use & Care Guide



**CONTINUOUS-CLEANING GAS RANGE
SF330PEW (Shown)
STANDARD-CLEANING GAS RANGE
SF310PEW**

Contents

	Page
Important Safety Instructions	3
Using Your Range	6
Using the surface burners	6
Setting the clock.....	7
Using the Minute Timer	8
Using the oven control	9
Baking/roasting	9
Adjusting the oven temperature control	10
Broiling	11
The oven vent	12
Caring For Your Range	12
Control panel and knobs	13
Surface burner grates and reflector pans	14
Surface burners	15
Removable cooktop	15
Removable oven door	16
Removable broiler carriage	17
Using the standard-cleaning oven .	18
Using the continuous-cleaning oven	18
Cleaning tips	21
The oven light	23
If You Need Service Or Assistance	24
Whirlpool Cooking Product Warranty	28

©1992 Whirlpool Corporation

Thank you for buying a Whirlpool appliance. Please complete and mail the Owner Registration Card provided with this product. Then complete the form below. Have this information ready if you need service or call with a question.

- Copy model and serial numbers from plate (located under cooktop) and purchase date from sales slip.
- Keep this book, the Cooking Guide and sales slip together in a handy place.

Model Number

Serial Number

Purchase Date

Service Company Phone Number

You are responsible for:

- Installing and leveling the range on a floor strong enough to support its weight, and where it is protected from the elements. (See the Installation Instructions.)
- Making sure the range is not used by anyone unable to operate it properly.
- Properly maintaining the range.
- Using the range only for jobs expected of a home range.
- Making sure the range is secured by properly installed anti-tip bracket.

Important Safety Instructions

Gas ranges have been thoroughly tested for safe and efficient operation. However, as with any appliance, there are specific installation and safety precautions which must be followed to ensure safe and satisfactory operation.

⚠ WARNING

To reduce the risk of fire, electrical shock, injury to persons, or damage when using the range, follow basic precautions, including the following:

WARNING: If the information in this manual is not followed exactly, a fire or explosion may result causing property damage, personal injury or death.

DO NOT STORE OR USE GASOLINE OR OTHER FLAMMABLE VAPORS AND LIQUIDS IN THE VICINITY OF THIS OR ANY OTHER APPLIANCE.

WHAT TO DO IF YOU SMELL GAS:

- **DO NOT TRY TO LIGHT ANY APPLIANCE.**
- **DO NOT TOUCH ANY ELECTRICAL SWITCH; DO NOT USE ANY PHONE IN YOUR BUILDING.**
- **IMMEDIATELY CALL YOUR GAS SUPPLIER FROM A NEIGHBOR'S PHONE. FOLLOW THE GAS SUPPLIER'S INSTRUCTIONS.**
- **IF YOU CANNOT REACH YOUR GAS SUPPLIER, CALL THE FIRE DEPARTMENT.**

INSTALLATION AND SERVICE MUST BE PERFORMED BY A QUALIFIED INSTALLER, SERVICE AGENCY OR THE GAS SUPPLIER.

Important Safety Instructions Continued

- Install or locate the range only in accordance with the provided Installation Instructions. The range must be installed by a qualified installer. The range must be properly connected to the proper gas supply and checked for leaks. The range must also be properly connected to electrical supply and grounded.

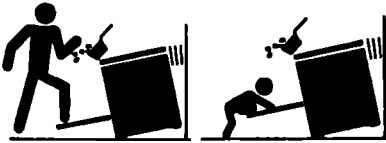

- **WARNING:** To reduce the risk of tipping of the appliance, the appliance must be secured by properly installed anti-tip bracket. To check if the bracket is installed properly, shine a flashlight under range toward left rear corner and verify that anti-tip bracket is engaged. See Installation Instructions for further details.
- Gas fuels and their use in appliances can cause minor exposures to benzene, formaldehyde, carbon monoxide and soot, primarily from incomplete combustion. Significant exposure to these substances can cause cancer or reproductive harm. Properly adjusted burners with a blue, rather than a yellow, flame will minimize incomplete combustion. Venting with a hood or an open window will further minimize exposure.
- Do not operate the range if it is damaged or not working properly.
- Do not use the range for warming or heating the room. Persons could be burned or injured, or a fire could start.
- Do not attempt to light the oven burner during a power failure. Personal injury could result. Reset oven controls to the off position in the event of a power failure.
- Use the range only for its intended use as described in this manual.
- Do not wear loose or hanging garments when using the range. They could ignite if they touch a hot surface burner and you could be burned.
- **DO NOT TOUCH SURFACE BURNERS, AREAS NEAR BURNERS OR INTERIOR SURFACES OF OVEN.** Areas near surface burners and interior surfaces of an oven become hot enough to cause burns. During use, do not touch, or let clothing or other flammable materials contact surface burners, areas near surface burners or interior surfaces of oven. Other surfaces of the range may become hot enough to cause burns; such as, the oven vent opening, the surface near the vent opening, the cooktop, the oven door and window.
- Make sure the utensils you use are large enough to contain food and avoid boilovers and splillovers. Heavy splattering or splillovers left on a range can ignite and burn you. Pan size is especially important in deep fat frying.
- Turn pan handles inward, but not over other surface burners. This will help reduce the chance of burns, igniting of flammable materials, and spills due to bumping of the pan.
- Use only dry potholders. Moist or damp potholders on surface burners may result in burns from steam. Do not let potholder touch surface burners. Do not use a towel or bulky cloth for a potholder. It could catch on fire.

- Check to be sure glass cooking utensils are safe for use on the range. Only certain types of glass, glass-ceramic, ceramic, earthenware or other glazed utensils are suitable for ranges without breaking due to the sudden change in temperature.
- Do not use decorative covers or trivets over the surface burners.
- Do not heat unopened containers. They could explode. The hot contents could cause burns and container particles could cause injury.
- Grease is flammable. Do not allow grease to collect around cooktop or in vents. Wipe spillovers immediately.
- Do not use water on grease fires. Never pick up a flaming pan. Smother flaming pan on range by covering with a well-fitted lid, cookie sheet or flat tray. Flaming grease outside of pan can be extinguished with baking soda or, if available, a multipurpose dry chemical or foam-type extinguisher.
- Never leave surface burners unattended at high heat settings. A boilover could result and cause smoking and greasy spillovers that may ignite.
- Use care when opening oven door. Let hot air or steam escape before removing or replacing food.
- Always position oven rack(s) in desired location while oven is cool.
- Do not store flammable materials on or near the range. The fumes can create an explosion and/or fire hazard.
- Do not store things children might want above the range. Children could be burned or injured while climbing on it.
- Do not leave children alone or unattended in area where the range is in use. They should never be allowed to sit or stand on any part of the range. They could be burned or injured.
- Do not use the oven for storage.
- Never use a match or other flame to look for a gas leak. Explosion and injury could result.
- Know where your main gas shutoff valve is located.
- Keep range vents unobstructed.
- Clean your range regularly. See care and cleaning instructions in this manual.
- Do not clean door seal. It is essential for a good seal. Care should be taken not to rub, damage, or move the seal. Clean only parts recommended in this Use and Care Guide.
- Do not use oven cleaners on continuous-cleaning ovens. No commercial oven cleaner or oven liner protective coating of any kind should be used in or around any part of the oven.
- Do not repair or replace any part of the range unless specifically recommended in this manual. All other servicing should be referred to a qualified technician.
- Disconnect the electrical supply before servicing the range.

– SAVE THESE INSTRUCTIONS –

Using Your Range

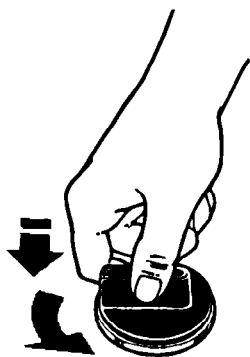

Surface burner marker

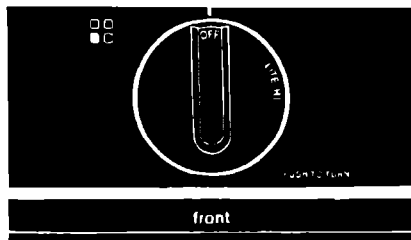

Using the surface burners

Your cooktop is equipped with electric ignitors. Electric ignitors automatically light the burners each time they are used.

Control knobs must be pushed in and turned to the LITE position. The clicking sound is the ignition sparking. **Visually check that burner has lit.**

To stop the clicking sound after the burner lights, turn the control knob back to a desired setting.

Surface burner markers

The solid dot in the surface burner marker shows which surface burner is turned on by that knob.

Burner heat settings

Until you get used to the settings, use the following as a guide. For best results, start cooking at the high settings; then turn the control knob down to continue cooking.

Use LITE to light the burner. After the burner lights, turn control back to a desired setting to stop the clicking of the ignition.

Use HI to start foods cooking; to bring liquids to a boil.

Use a medium setting to continue cooking or to fry chicken or pancakes; for gravy, pudding and icing; to cook large amounts of vegetables.

Use a low setting to keep food warm until ready to serve.

NOTE: Do not cook with the control in the LITE position.

Use correct burner heat settings. If the heat setting is too high, it can:

- Char bacon and cause curling.
- Make eggs tough and crisp at the edges.
- Toughen liver, fish and seafood.
- Scorch delicate sauces and custards.
- Cause a boilover.

In case of a prolonged power failure: Surface burners can be manually lighted. Hold a lighted match near a burner and turn the control to the LITE position. After the burner lights, turn the control to the desired setting.

⚠ WARNING

Burn, Fire and Explosion Hazard

- Burner flame should not extend beyond the edge of the cooking utensil. The flame can burn you and cause poor cooking results.
- Be sure all control knobs are turned to OFF when you are not cooking. Someone could be burned or a fire could start if a burner is accidentally left ON.
- If the flame should go out while cooking, or if there is a strong gas odor, turn the burners OFF. Wait five minutes for the gas odor to disappear before relighting burner. If gas odor is still present, see safety note on page 3. Failure to follow these precautions could result in explosion or fire.



Setting the clock

When the range is connected to power, the clock display will blink at "88:88" until the time of day is set.

1. Push and hold the Set button while turning the Set Knob in either direction to the correct time of day.
2. Release the Set button after the time of day is set.

Using Your Range Continued



Using the Minute Timer

The Minute Timer does not start or stop the oven. It works like a kitchen timer. It can be set in minutes and seconds up to 60 minutes.

1. Turn the Set Knob clockwise to the desired setting (up to 60 minutes). The Minute Timer will count down and the colon will flash. When the set time is up, a tone will sound.
2. Press the Set button. The tone will stop and the display will show the time of day.

To check time of day when using Minute Timer:

Push and hold the Set button. The time of day will appear.

To return to the Minute Timer display:

Release the Set button. The Minute Timer will continue to count down.

To cancel the Minute Timer before the countdown is completed:

Turn the Set Knob to "0:00". If no other time is set within three seconds, the time of day will reappear on the display.

Using the oven control

Baking/roasting

1. Position the rack(s) properly before turning on the oven. To change rack position, pull rack out to stop, raise front edge and lift out.

When using one rack, the rack should be placed so the top of the food will be centered in the oven. Always leave at least 1½ to 2 inches (4-5 cm) between the sides of the pan and the oven walls and other pans. For more information, see the Cooking Guide.

2. Push in and turn the Oven Temperature Control to the baking/roasting temperature you want. The oven burner will automatically light in 50-60 seconds.

3. When baking, preheat the oven for 10 minutes. Put food in the oven.

NOTE: Do not preheat when roasting or cooking items such as casseroles.

Do not place food directly on the oven bottom.

4. During baking/roasting, the oven burner will turn on and off to maintain the temperature setting.

5. When baking/roasting is done, turn the Oven Temperature Control to OFF.

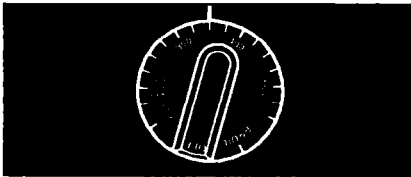

oven temp

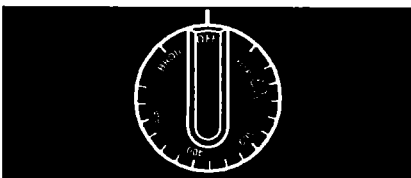
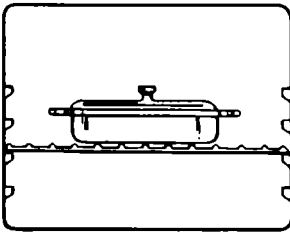

oven temp

Using Your Range Continued

Adjusting the oven temperature control

Does your oven seem hotter or colder than your old oven? The temperature of your old oven may have shifted gradually without you noticing the change. Your new oven is properly adjusted to provide accurate temperatures. But, when compared to your old oven, the new design may give you different results.

If, after using the oven for a period of time, you are not satisfied with the temperature settings, they can be adjusted by following these steps:

1. Turn the Oven Temperature Control Knob to the off position. Pull knob straight off and flip it over.

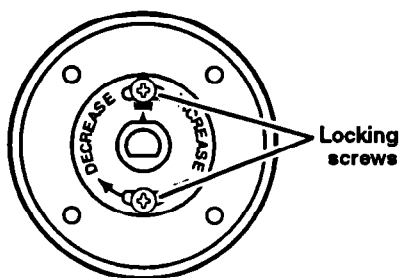

2. Loosen the locking screws. Note the position of the indicator.

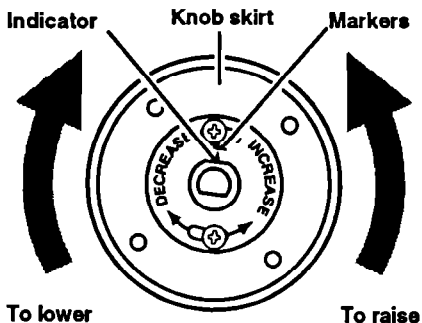

3. To lower the temperature, hold knob handle firmly and turn knob skirt clockwise to move the indicator one marker line to the left. Each line equals about 10°F (5°C).
4. To raise the temperature, hold knob handle firmly and turn knob skirt counterclockwise to move the indicator one marker line to the right. Each line equals about 10°F (5°C).

Tighten the locking screws and replace the control knob.

Broiling

The broiler drawer is located below the oven door. **Always broil with the oven door closed.**

1. Pull the broiler drawer open. Broiler door will tilt down when opened.

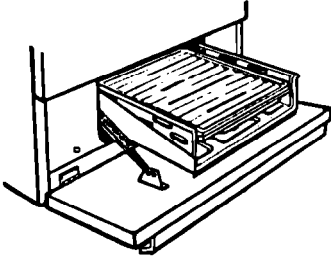

⚠ CAUTION

Product Damage Hazard

Do not step on or apply excess weight to broiler door when open.

Doing so can damage the door.

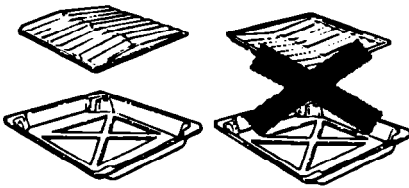

2. Place broiler pan grid so grease can drain down sides into lower part of broiler pan. See picture.
3. Before the broiler is turned on, place food on broiler pan and position the broiler pan at one of the three levels. Refer to a reliable cookbook for broiling chart.

4. Push in and turn the Oven Temperature Control to BROIL. The broiler will automatically light in 50-60 seconds.
5. When broiling is done, turn the Oven Temperature Control to OFF.

NOTE: Do not preheat the broiler before using. Completely close the broiler drawer during broiling.

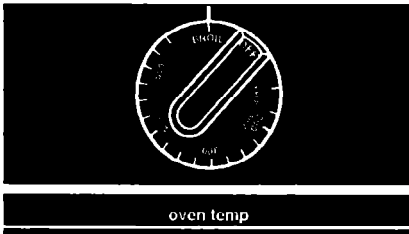

Using Your Range Continued

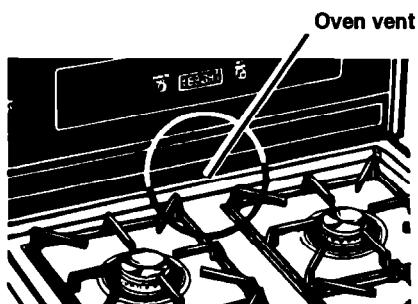

The oven vent

Hot air and moisture escape from the oven through a vent just under the backguard. The vent is needed for air circulation. **Do not block the vent.** Poor baking/roasting will result.

NOTE: Never store plastics, paper or other items that could melt or burn near the oven vent, or any of the surface burners.

⚠ WARNING

Burn Hazard

When the oven is **ON**, pans and pan handles left near the oven vent can become hot enough to burn the user and to melt plastics. Use potholders to move pans.

Caring For Your Range

⚠ WARNING

Burn, Electrical Shock, Fire and Explosion Hazard

- Make sure all controls are **OFF** and the range is cool before cleaning.
- Do not use oven cleaners, bleach or rust removers.
- Do not obstruct the flow of combustion and ventilation air.

Failure to follow these guidelines could result in burns, electrical shock, fire or explosion.

Control panel and knobs

1. Make sure all control knobs are turned to OFF.
2. Pull control knobs straight off.

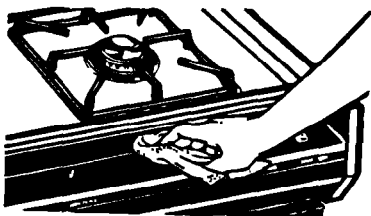
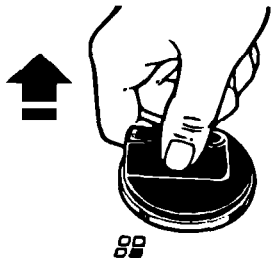

3. Use warm, soapy water and a sponge or spray glass cleaner and a paper towel to wipe the control panels. Rinse and wipe dry with a soft cloth.



4. Wash control knobs with warm, soapy water and a sponge. Rinse well and dry with a soft cloth. Do not soak.

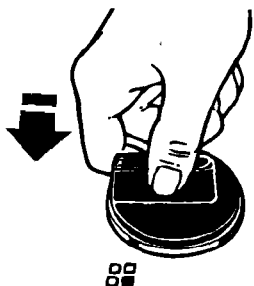

5. Replace control knobs by pushing them firmly into place.

NOTE: When cleaning, never use steel wool, abrasives, or commercial oven cleaners which may damage the finish. After cleaning, make sure all control knobs point to OFF.

Caring For Your Range Continued

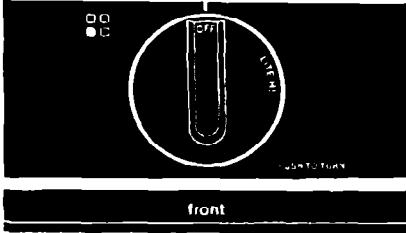

Surface burner grates and reflector pans

1. Make sure all surface burners are off and the surrounding parts are cool.

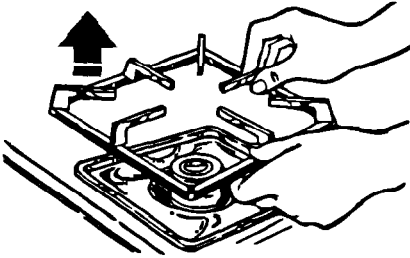

2. Lift off the burner grates and remove reflector pans.

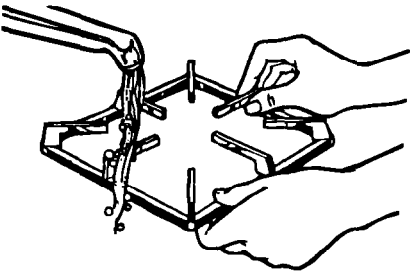

3. Wash the grates and reflector pans with warm, soapy water or in a dishwasher. Use a nonabrasive plastic scrubbing pad for cooked-on foods. Rinse and dry well.

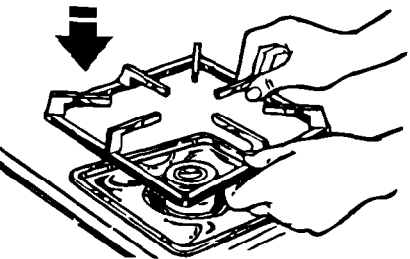

4. Replace reflector pans and burner grates.

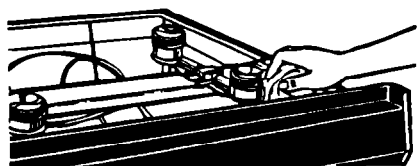

Surface burners

To remove the cooktop, follow the instructions in "Removable cooktop" below.

Wipe off surface burners with warm, soapy water and a sponge after each use. Use a plastic scrubbing pad for cooked-on food.

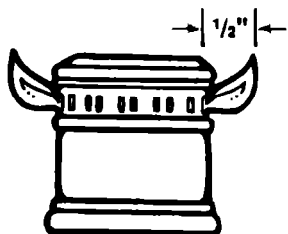

Typical surface burner flame at highest setting

Occasionally check the burner flames for proper size and shape as shown below. A good flame is blue in color. If flames lift off ports, are yellow, or are noisy when turned off, you may need to clean the burners (see "Cleaning tips" on page 21), or call a qualified technician for adjustment.

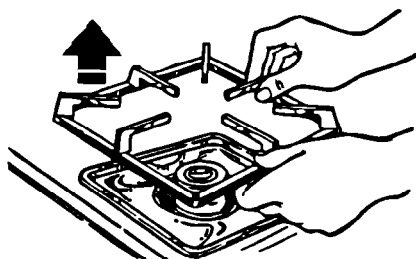

Removable cooktop

1. Remove surface burner grates and reflector pans.

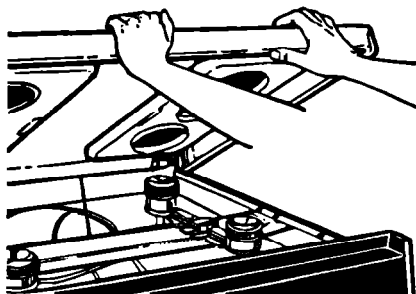

2. Lift front of cooktop enough to clear front of range. Grasp both sides of the cooktop, lift and pull forward to remove.

Caring For Your Range Continued

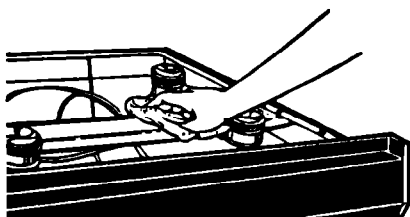

3. Wipe surface under the cooktop with warm, soapy water and a sponge. Use a soap-filled plastic scrubbing pad on heavily soiled areas.
4. Replace cooktop by fitting studs on back of cooktop into guide holes in rear vertical supports. Lower front of cooktop. Avoid hitting the control panel. Replace reflector pans and surface burner grates.

⚠ WARNING

Personal Injury and Product Damage Hazard

- Do not try to clean under the cooktop without removing it first. The cooktop could accidentally fall and injure you.
- Do not drop the cooktop. Damage can result to the porcelain and the cooktop frame.

Removable oven door

Removing the oven door will help make it easier to clean the oven.

⚠ WARNING

Burn and Electrical Shock Hazard
Make sure all controls are OFF and the oven is cool before removing oven door.

Failure to do so can result in burns or electrical shock.

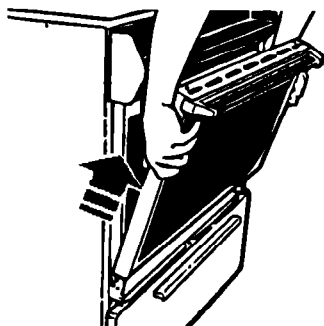

1. Open the door to the first stop position.
2. Hold the door at both sides and lift it at the same angle it is in.
3. To replace, fit the bottom corners of the door over the ends of the hinges. Push the door down evenly. The door will close only when it is on the hinges correctly.

Removable broiler carriage

The broiler carriage can be removed for easier cleaning.

To remove:

1. Pull broiler drawer open. Broiler door will tilt down when opened.
2. Remove the broiler pan and grid.

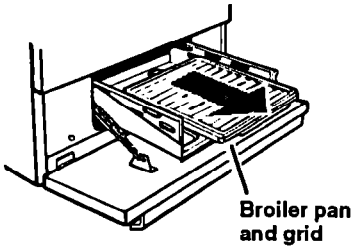

3. Slightly lift broiler carriage and pull all the way out.

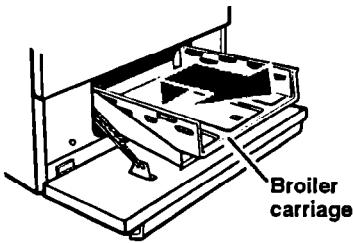

To replace:

1. Push broiler carriage in until carriage is locked under placement tab in rear of broiler carriage body. Make sure spring clip at front of carriage snaps into slot in broiler carriage body. **Carriage must be snapped into body whenever you are baking.**
2. Replace broiler pan and grid.
3. Close broiler drawer all the way.

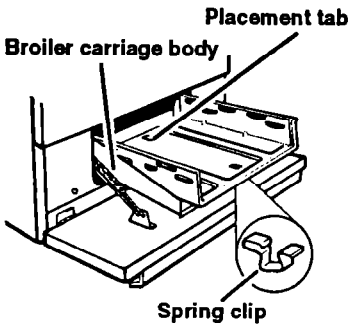

Using the standard- cleaning oven (Model SF310PEW)

The standard-cleaning oven has to be hand-cleaned. Use warm soapy water, soapy steel-wool pads or a commercial oven cleaner. See "Cleaning tips" on page 21 for further instructions.

CAUTION

Product Damage Hazard

Do not allow commercial oven cleaner to contact the heat seal, thermostat or exterior surfaces of the oven. Damage will occur.

Use foil during cooking to keep oven clean. See "Using foil" on page 20 for more information.

Fat spatter
beads up.
Turns black.

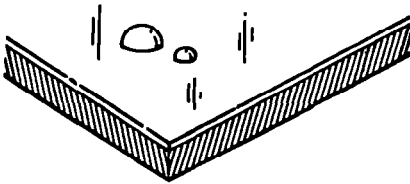

Standard
porcelain

Fat spatter
spreads out.
Burns away.

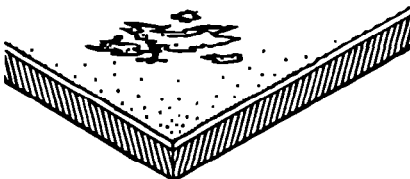

Continuous-
cleaning
porcelain

Using the continuous- cleaning oven (Model SF330PEW)

Standard-cleaning oven walls are coated with smooth porcelain. Your continuous-cleaning oven walls are coated with a special, rougher porcelain. A fat spatter beads up on the smooth surface, but spreads out on the rougher surface. The bead of fat on the smooth surface chars and turns black. The spread-out fat on the rough surface gradually burns away at medium to high baking temperatures so the oven can return to a presentably clean condition.

Cleaning tips

- The oven window and racks are not coated. Clean them by hand.
- The oven door does not get as hot as the walls. Some hand-cleaning may be needed.
- If you do more broiling than baking, hand-cleaning may be needed.

Hand-cleaning the continuous-cleaning oven

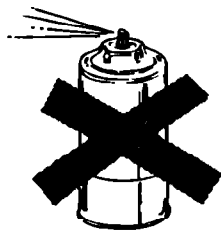

⚠ WARNING

Personal Injury Hazard

Do not use oven cleaning products in a continuous-cleaning oven. Some can become trapped in the porcelain surface and give off harmful fumes.

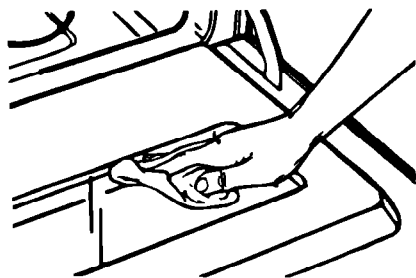

WINDOW – Keep clean with warm, soapy water or spray glass cleaner. Use a plastic scrubbing pad for heavily soiled areas. Rinse well. **Do not use steel wool or abrasive cleansers.**

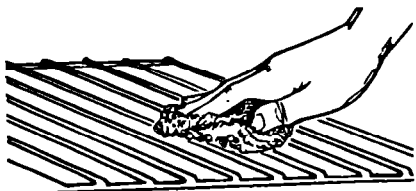

RACKS – Use a soapy steel-wool pad for best cleaning results. Rinse well.

Caring For Your Range Continued

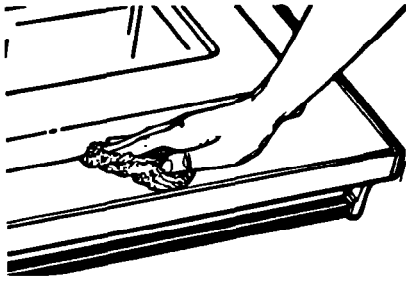

WALLS AND DOOR – Wash with warm soapy, water. Use a steel-wool pad or plastic scrubbing pad for heavily soiled areas. Rinse well.

Using foil (standard and continuous-cleaning ovens)

To catch sugar or starchy spills from pies and casseroles, use a piece of heavy-duty aluminum foil or a shallow pan on the lower rack, slightly larger than the cooking container.

⚠ WARNING

Burn, Electrical Shock and Product Damage Hazard

- **Make sure all controls are OFF and the oven is cool before using foil. Failure to do so can result in burns or electrical shock.**
- **Do not use foil to cover oven floor or to completely cover a rack. Good air circulation is needed for the oven to operate properly. Poor cooking results and damage to the oven could occur.**

1. Turn off all controls.
2. Put foil or pan under the cooking container. Make sure the foil is centered and large enough to catch any spillovers.

Cleaning tips

Control knobs

Clean with warm, soapy water and a sponge.

- Wash, rinse and dry well.
- Do not soak.

Control panels

Clean with warm, soapy water and a sponge or spray glass cleaner and a paper towel.

- Wash, rinse and dry well.
- Follow directions provided with the cleaner.

Exterior surfaces (other than control panels)

Clean with warm, soapy water and a sponge.

- Wipe off regularly when cooktop and oven are cool.

Use a nonabrasive plastic scrubbing pad for heavily soiled areas.

- Do not use abrasive or harsh cleaners.

NOTE: Do not allow food containing acids (such as vinegar, tomato or lemon juice) to remain on surface. Acids may remove the glossy finish. Also, wipe up milk or egg spills when cooktop is cool. Be careful when cleaning around model and serial number plate; the numbers wipe off easily.

Surface burners

Clean with warm, soapy water and a sponge.

- Remove cooktop (see page 15).
- Wipe off spills immediately after burner has cooled.

For cooked-on food:

- Remove burner from manifold with Phillips screwdriver.
- Wash with warm, soapy water and a nonabrasive plastic scrubbing pad.
- Rinse and dry well.
- If ports are clogged, clean with a straight pin. **Do not enlarge or distort port. Do not use a wooden toothpick.**
- Do not clean surface burner in dishwasher.

Surface burner grates and chrome reflector pans

Clean with warm, soapy water and a nonabrasive plastic scrubbing pad.

- Wash, rinse and dry well.

OR

Clean in a dishwasher.

Broiler drawer, pan and grid

Clean with warm, soapy water and a steel-wool pad.

- Clean after each use.
- Wash, rinse and dry well.
- **After broiler is cool**, wipe interior with warm, damp sponge. For heavily soiled areas, use a soapy steel-wool pad.

Oven racks

Clean with warm, soapy water and steel-wool pads.

- Wash, rinse and dry.

Oven door glass

Use spray glass cleaner and a paper towel or warm, soapy water and a non-abrasive plastic scrubbing pad.

- Make sure oven is cool.
- Follow directions provided with the cleaner.
- Wash, rinse and dry well.

Caring For Your Range Continued

Standard-cleaning oven

Clean with warm, soapy water and a sponge or soapy steel-wool pads.

- Make sure oven is cool.
- Remove door for easier access.
- Clean heavily soiled areas or stains. Rinse well with water.

OR

Use commercial oven cleaners.

- Remove door for easier access.
- Place newspaper on floor to protect floor surface.
- Follow directions provided with the oven cleaner.
- Rinse well with clear water.
- Use in well-ventilated room.
- **Do not allow commercial oven cleaners to contact the heat seal, thermostat or exterior surfaces of the range. Damage will occur.**

Place piece of heavy-duty aluminum foil or shallow pan, slightly larger than the cooking container, on lower rack to catch spillovers.

Continuous-cleaning oven

Clean with warm, soapy water or a soapy steel-wool pad.

- Make sure oven is cool.
- Remove door for easier access.
- Clean heavily soiled areas or stains. Rinse well with water.

Place piece of heavy-duty aluminum foil or shallow pan, slightly larger than the cooking container, on lower rack to catch spillovers.

- **Do not use commercial oven cleaners.**
- **Most fat splatters on oven walls and floor will gradually reduce to a presentably clean condition during baking.**

The oven light

The oven light will come on when you push the Oven Light Switch on the control panel. Push the switch again to turn off the light.

⚠ WARNING

Electrical Shock and Personal Injury Hazard

- Make sure oven and light bulb are cool and power to the oven has been turned off before replacing the light bulb. Failure to do so could result in electrical shock or burns.
- Be careful not to drop the bulb. Broken glass could cause injury.

To replace the oven light:

1. Unplug appliance or disconnect at the main power supply.
2. Remove the light bulb from its socket. Replace with a 40-watt appliance bulb. Plug in appliance or reconnect at the main power supply.

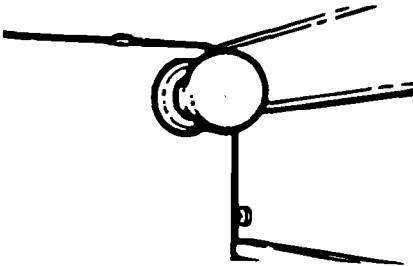
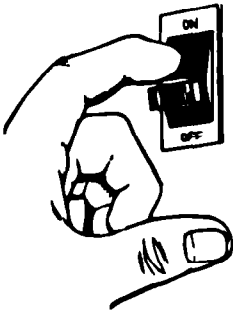

If You Need Service Or Assistance ...

We suggest you follow these steps:

1. Before calling for assistance ...

Performance problems often result from little things you can find and fix without tools of any kind.

If nothing operates:

- Is the gas turned on?
- Is the power supply cord plugged into a live circuit with the proper voltage? (See Installation Instructions.)
- Have you checked your home's main fuses or circuit breaker box?
- Have instructions in this book been followed?
- Is the control knob set in the correct position?
- Is the flow of combustion and/or ventilation air to the unit obstructed?
Do not obstruct airflow to and around unit.
- Recheck suspected defect.

If the oven will not operate:

- Is the Oven Temperature Control turned to a temperature setting?

If burner fails to light:

- Is the range connected to electrical power?
- Have you checked your home's main fuses or circuit breaker box?
- Are burner ports clogged?
See page 21.

If burner flames are uneven:

- Are burner ports clogged?
See page 21.

If burner flames lift off ports, are yellow, or are noisy when turned off:

- The air/gas mixture may be incorrect. (Call for service.)

If burner makes a popping noise when ON:

- Is the burner wet from washing?
Let dry.

If control knob(s) will not turn:

- Did you push in before trying to turn?

If soil is visible on continuous-cleaning oven finish:

- The special finish is designed to **gradually reduce oven soil** during normal baking or roasting. It is not designed to keep your oven spotless, only presentably clean. If you broil often, you may see oven soil. Follow hand-cleaning tips on page 19.
- The door is cooler than the oven walls. Soil will be more visible on the door than other areas in the oven. See hand-cleaning tips on page 19.
- Sugar and starchy spills may leave stains. See page 19 for hand-cleaning tips. **Use foil on lower rack to catch these spills.**

If cooking results are not what you expected:

- Is the range level?
- Does the oven temperature seem too low or too high? See page 10.
- If needed, have you preheated the oven as the recipe calls for?
- Does the flame size fit the cooking utensil being used? (See the Cooking Guide.)
- Are you following a tested recipe from a reliable source?
- Are you using pans recommended in the Cooking Guide?
- If baking, have you allowed 1 ½ to 2 inches (4-5 cm) on all sides of the pans for air circulation?
- Are the pans the size called for in the recipe?
- Do the cooking utensils have smooth, flat bottoms and fit the surface burners being used?

See the Cooking Guide for more information on cooking problems and how to solve them.

2. If you need assistance* ...

Call Whirlpool Consumer Assistance Center telephone number. Dial free from anywhere in the U.S.:
1-800-253-1301

and talk with one of our trained consultants. The consultant can instruct you in how to obtain satisfactory operation from your appliance or, if service is necessary, recommend a qualified service company in your area.

If you prefer, write to:

Mr. William Clark
 Consumer Assistance Representative
 Whirlpool Corporation
 2000 M-63
 Benton Harbor, MI 49022

Please include a daytime phone number in your correspondence.

3. If you need service* ...



Whirlpool has a nationwide network of authorized WhirlpoolSM service companies.

Whirlpool service technicians are trained to fulfill the product warranty and provide after-warranty service, anywhere in the United States. To locate the authorized Whirlpool service company in your area, call our Consumer Assistance Center telephone number (see Step 2) or look in your telephone directory Yellow Pages under:

• APPLIANCE-HOUSEHOLD-MAJOR, SERVICE & REPAIR
 - See: Whirlpool Appliances or Authorized Whirlpool Service (Example: XYZ Service Co.)

• WASHING MACHINES & DRYERS, SERVICE & REPAIR
 - See: Whirlpool Appliances or Authorized Whirlpool Service (Example: XYZ Service Co.)

4. If you need FSP* replacement parts* ...

FSP is a registered trademark of Whirlpool Corporation for quality parts. Look for this symbol of quality whenever you need a replacement part for your Whirlpool appliance. FSP replacement parts will fit right and work right, because they are made to the same exacting specifications used to build every new Whirlpool appliance.

To locate FSP replacement parts in your area, refer to Step 3 above or call the Whirlpool Consumer Assistance Center number in Step 2.

5. If you are not satisfied with how the problem was solved* ...

- Contact the Major Appliance Consumer Action Panel (MACAP). MACAP is a group of independent consumer experts that voices consumer views at the highest levels of the major appliance industry.
- Contact MACAP only when the dealer, authorized servicer and Whirlpool have failed to resolve your problem.

Major Appliance Consumer Action Panel
 20 North Wacker Drive
 Chicago, IL 60606

- MACAP will in turn inform us of your action.
- When requesting assistance, please provide: model number, serial number, date of purchase, and a complete description of the problem. This information is needed in order to better respond to your request.

WHIRLPOOL® Gas Cooking Product Warranty

GR003

LENGTH OF WARRANTY	WHIRLPOOL WILL PAY FOR
FULL ONE-YEAR WARRANTY From Date of Purchase	FSP® replacement parts and repair labor to correct defects in materials or workmanship. Service must be provided by an authorized Whirlpool SM service company.
WHIRLPOOL WILL NOT PAY FOR	
A. Service calls to: <ol style="list-style-type: none"> 1. Correct the installation of the cooking product. 2. Instruct you how to use the cooking product. 3. Replace house fuses or correct house wiring or plumbing. 4. Replace owner accessible light bulbs. B. Repairs when the cooking product is used in other than normal, single-family household use. C. Pickup and delivery. This product is designed to be repaired in the home. D. Damage to the cooking product caused by accident, misuse, fire, flood, acts of God or use of products not approved by Whirlpool. E. Repairs to parts or systems caused by unauthorized modifications made to the appliance.	

WHIRLPOOL CORPORATION SHALL NOT BE LIABLE FOR INCIDENTAL OR CONSEQUENTIAL DAMAGES. Some states do not allow the exclusion or limitation of incidental or consequential damages, so this limitation or exclusion may not apply to you. This warranty gives you specific legal rights, and you may also have other rights which vary from state to state.

Outside the United States, a different warranty may apply. For details, please contact your authorized Whirlpool distributor or military exchange.

If you need service, first see the "Service or Assistance" section of this book. After checking "Service or Assistance," additional help can be found by calling our Consumer Assistance Center telephone number, 1-800-253-1301, from anywhere in the U.S.

® Registered Trademark/SM Service Mark of Whirlpool Corporation